

ZIEL BAGS + STAND

Specification Sheet

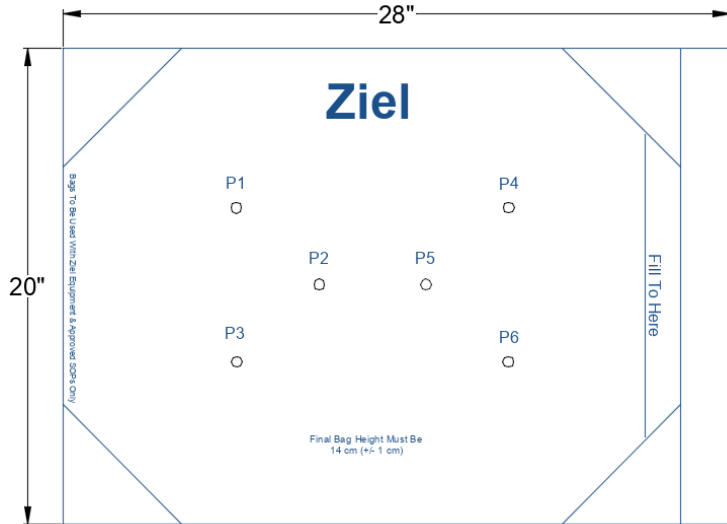

Bag Benefits

- 3 mil poly-nylon multi-layer material helps retain product quality
- Extensively tested and proven to be suitable for Radio Frequency
- FDA-approved food grade
- 28" x 20" (71.12 cm x 50.8 cm)
- Designed to fit Ziel's bag stand for easy filling
- Nominal fill capacity of 5 lb (2.2 kg)
- Pre-sealed bottom corners for faster bagging
- Bag designed to comply with Ziel SOPs and deliver repeatable results
- Faster onboarding for new operators

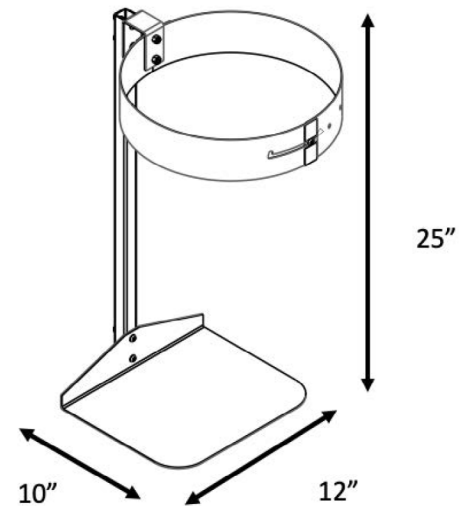

Ready to Use Bags, Improving your Efficiency

We used customer feedback and data from tens of thousands of processing runs to create a bag that works seamlessly with Ziel's current SOPs, optimizing your process.

With the template printed directly on the bag, these custom-designed and manufactured bags greatly reduce the potential for human error, making bagging cannabis for APEX machines easier and more efficient and providing robust and reliable processing outcomes.

To Purchase APEX Bags:

- Contact service@ziel.com
- Order Size: 200 bags per box, minimum 1 box

Stand Benefits

- Designed to sit on a pedestal-style scale for accurate real-time weighing
- Retention ring grips and holds bag upright for easy and efficient filling
- Reduces risk of spillage and overfilling
- Stainless steel construction for easy cleaning and durability
- 10" x 12" x 25" (25.4 cm x 30.5 cm x 63.5 cm)